



Center Finder Layout Jig



Center Finder

Pepetools Center Finder Layout Jig

The Pepetools center finder layout jig is one of those immensely useful tools, that you will find an invaluable addition to your workbench. It allows to you to quickly ascertain and mark the precise center of a round item....and much more besides. Here's how...

The jig is made from tough acrylic, in two sections bolted together. Important, do not unbolt the two halves. The large square plate is marked with a grid pattern that is parallel to the top and sides, with a vertical slot in the center, which you will use for making the material. The smaller section is cut at a right angle square, which is set at precisely 45 deg to the center slot.

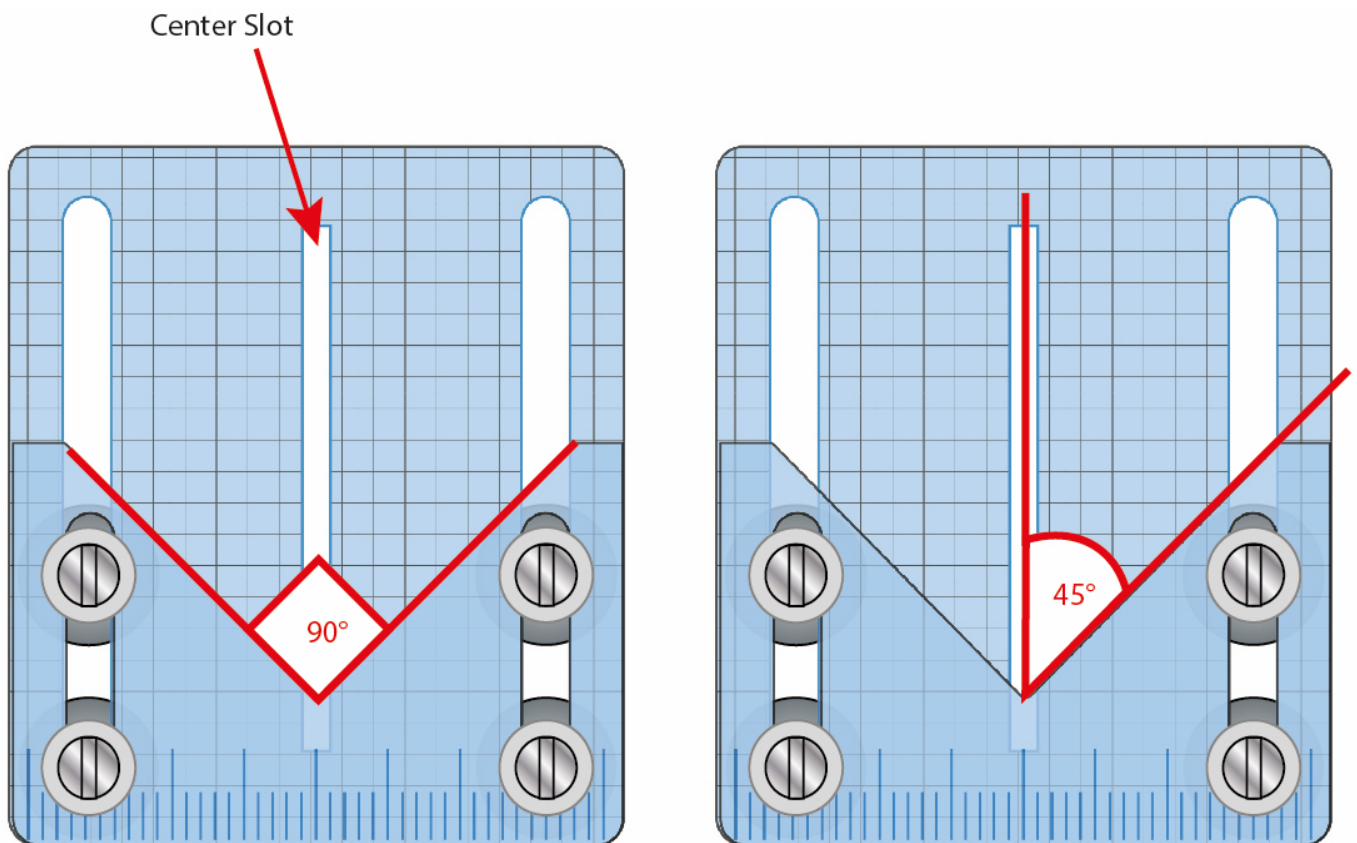

To use the jig, you will need something to mark with. Depending on the material you are working with, use either a scribe, pencil, or fine-tip marker pen. Ensure that the tip of the pen will go through the center slot.

Center Finder

Undoubtedly the most useful feature is its ability to find the center of a circular disc. This could be a small metal disc, such as part of a pendant, a coin, a stone, or a cabochon. Anything small and circular, up to 50 mm in diameter. In this case, we refer to a perfectly circular disc.

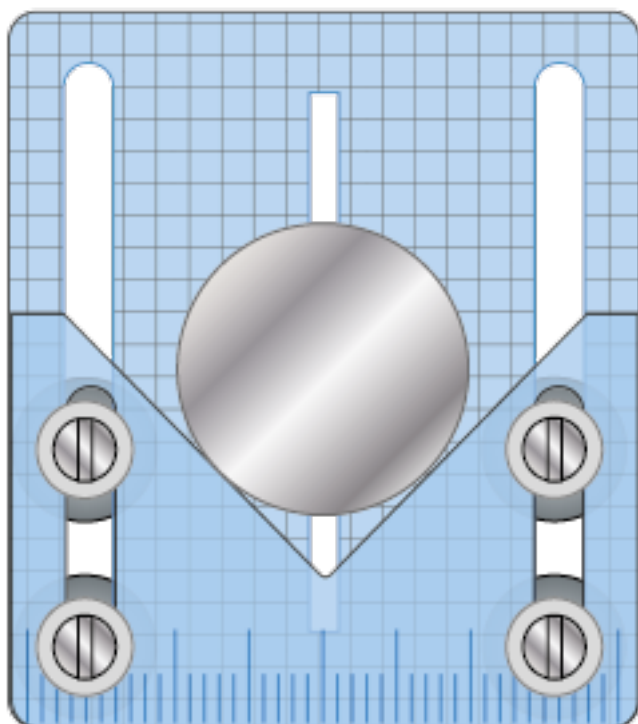

To begin, place the disc flat against the jig, in the middle of the V as shown. Make sure that the disc is touching both sides.

Whilst holding it in place, mark the disc from the other side, using a fine-tipped permanent marker pen, in the center slot. Mark a line across the disc from edge to edge.

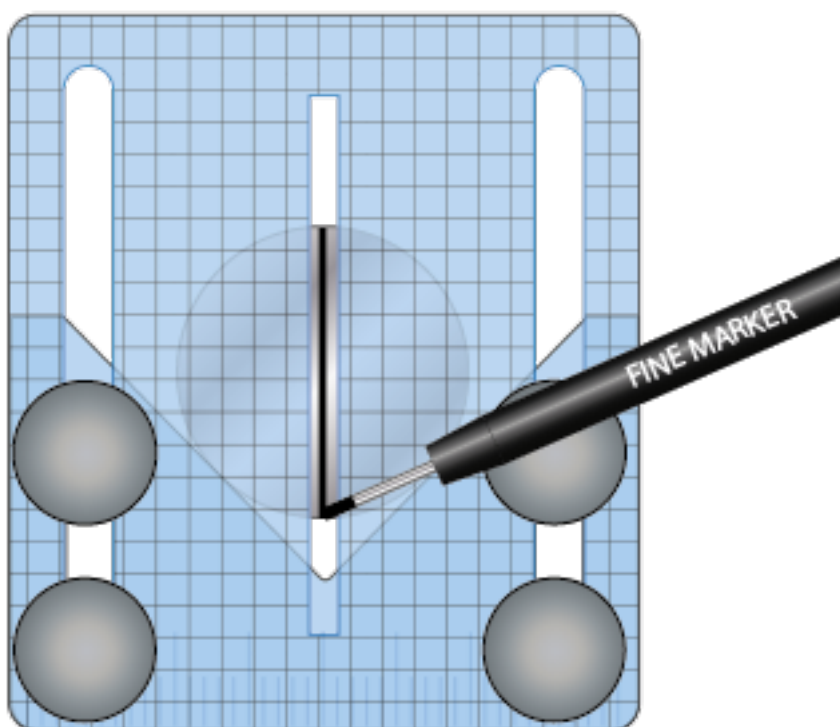

Center Finder

Rotate the disc approximately 90°. The cool thing here is that you don't need to be accurate, but you can use the lines on the grid to help. Mark the disc again, to form a cross.

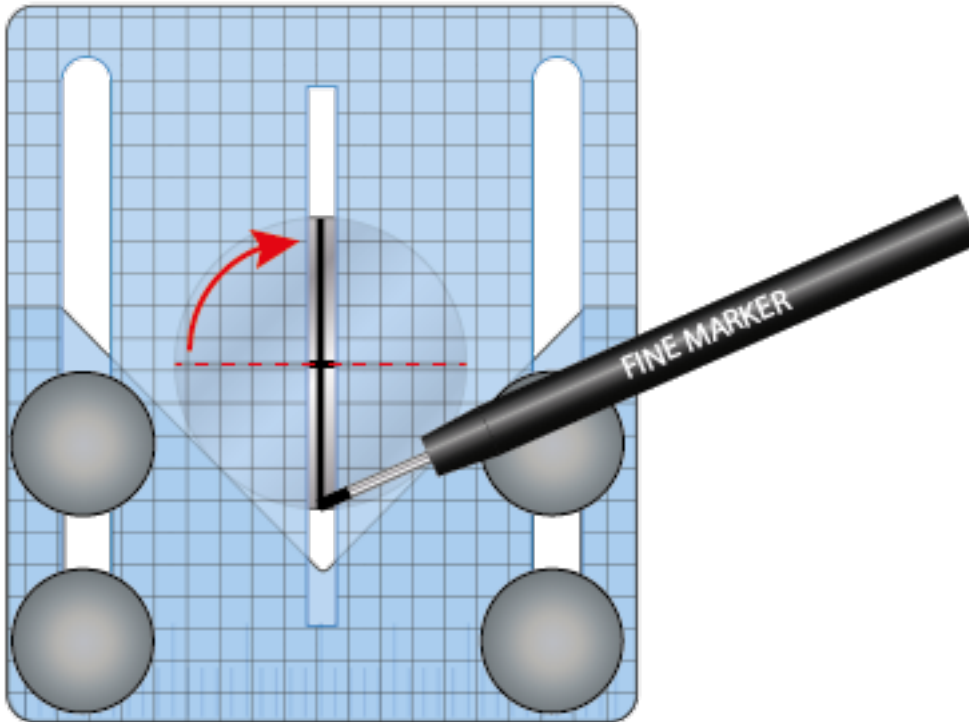

The point where the two lines cross is the exact center of the disc.

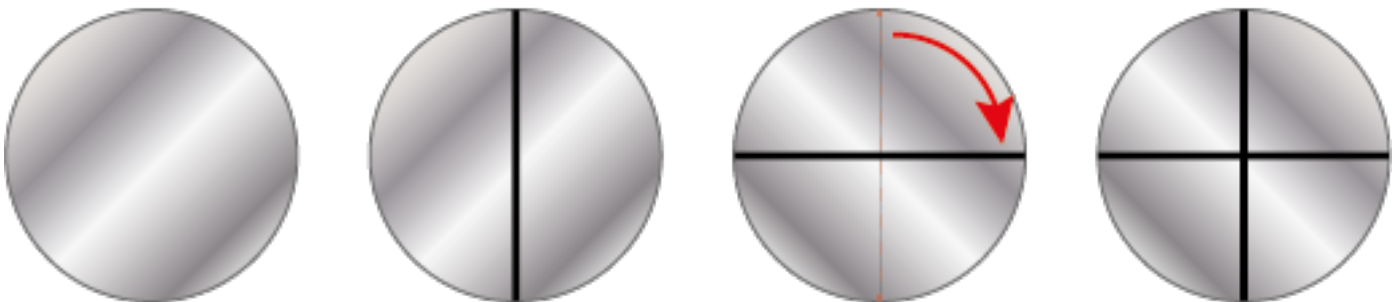

Using this quick and simple method, you can find the center of any circular disc, coin, or even the end of a bar. Note, the first line passes directly through the center of the disc and marks the diameter, effectively marking the disc into two separate and equal halves, should you want to saw something perfectly in half.

TIP: - this also works if the piece is perfectly square!

Center Finder

In the same way, you can mark a spot for drilling a hole, to add a jump ring or bail. If the disc has a design on it, you can use the gridlines on the jig to align it horizontally and then mark the center line vertically.

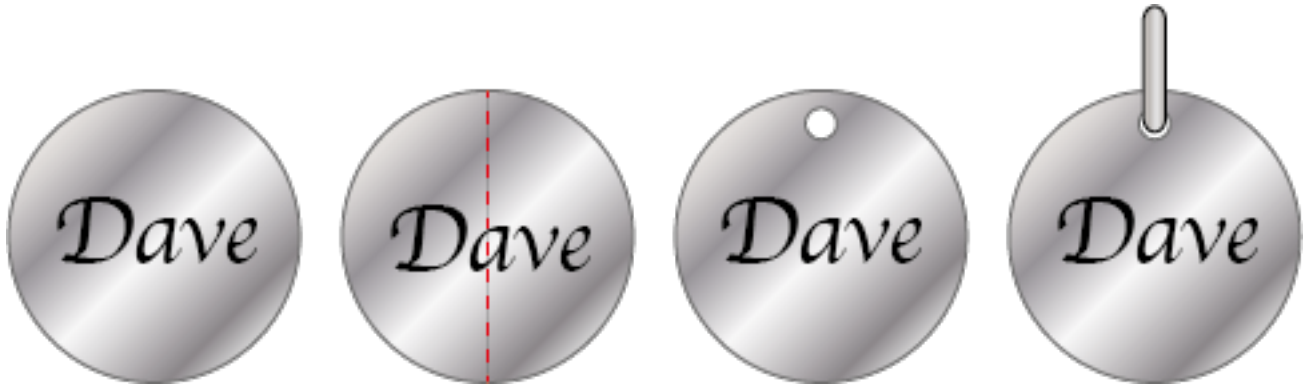

If you drill holes, along the center line they will always be in alignment and balanced. Perfect when making multiple drops for earrings or pendants. Likewise with square shapes. Place the square in the bottom of the v, and mark the center line, which should go from corner to corner. Rotate 90° and mark again to find the center spot.

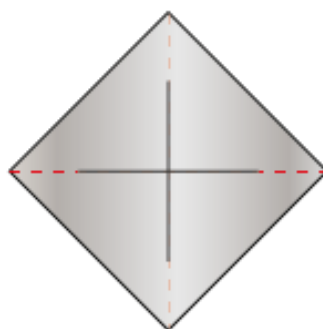
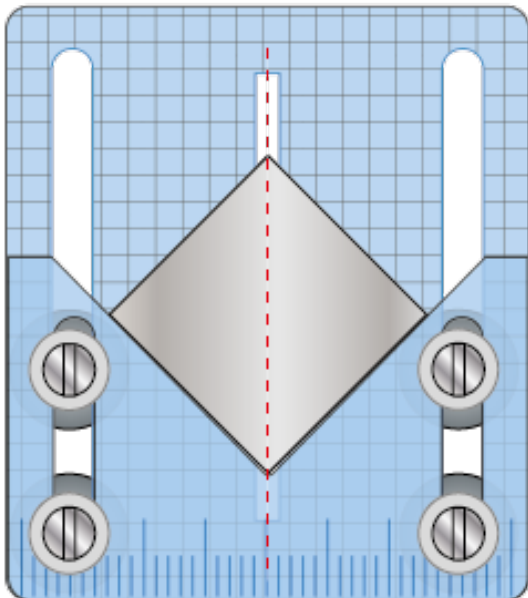
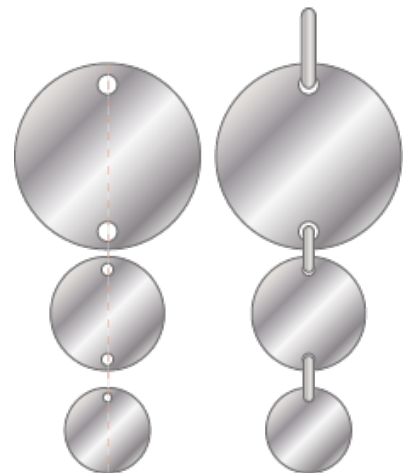

Rings

The Jig also has many uses when working with rings. If you need to cut the back of the ring for adjustment, simply align it in the jig with the front of the ring pointing upwards. Again, use the gridlines to ensure it is aligned and level. Mark down the center line of the ring, to find the midline of the shank.

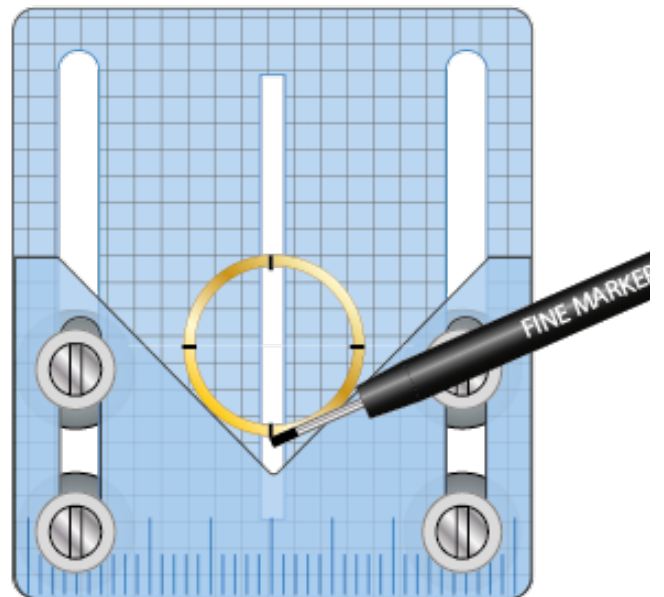
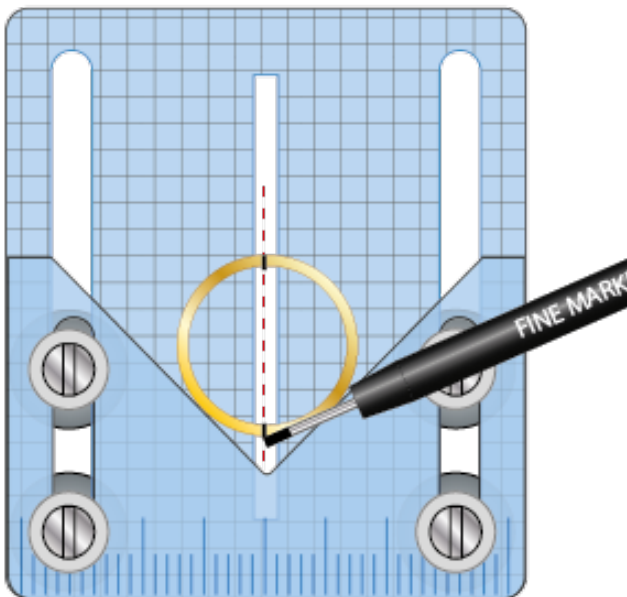
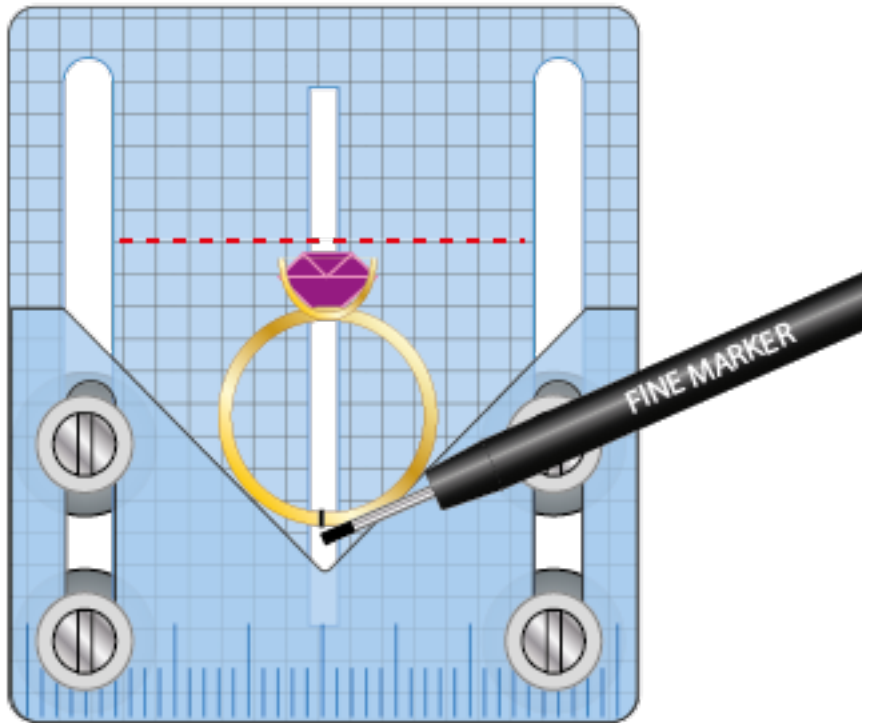

Just as you would mark a cross to find the center, you can mark the edges of the ring, then align it with the gridlines and mark again at 90° a quick way to align grooves or to mark details around the ring.

Tip: - This also works with washer components, made with the PePETools disc cutter.

Miter Joints

If you need to make miter joints at 45° for small frames, models. Etc. Start by ensuring the end of the strip is square (or as close as you can get it). Place the strip along one side of the V, ensuring that the end is at the bottom of the V. From the other side, use the center slot to mark a vertical line across the width. This will be at 45°. Cut the strip along the line. Do this with two strips to get the perfect right angle.

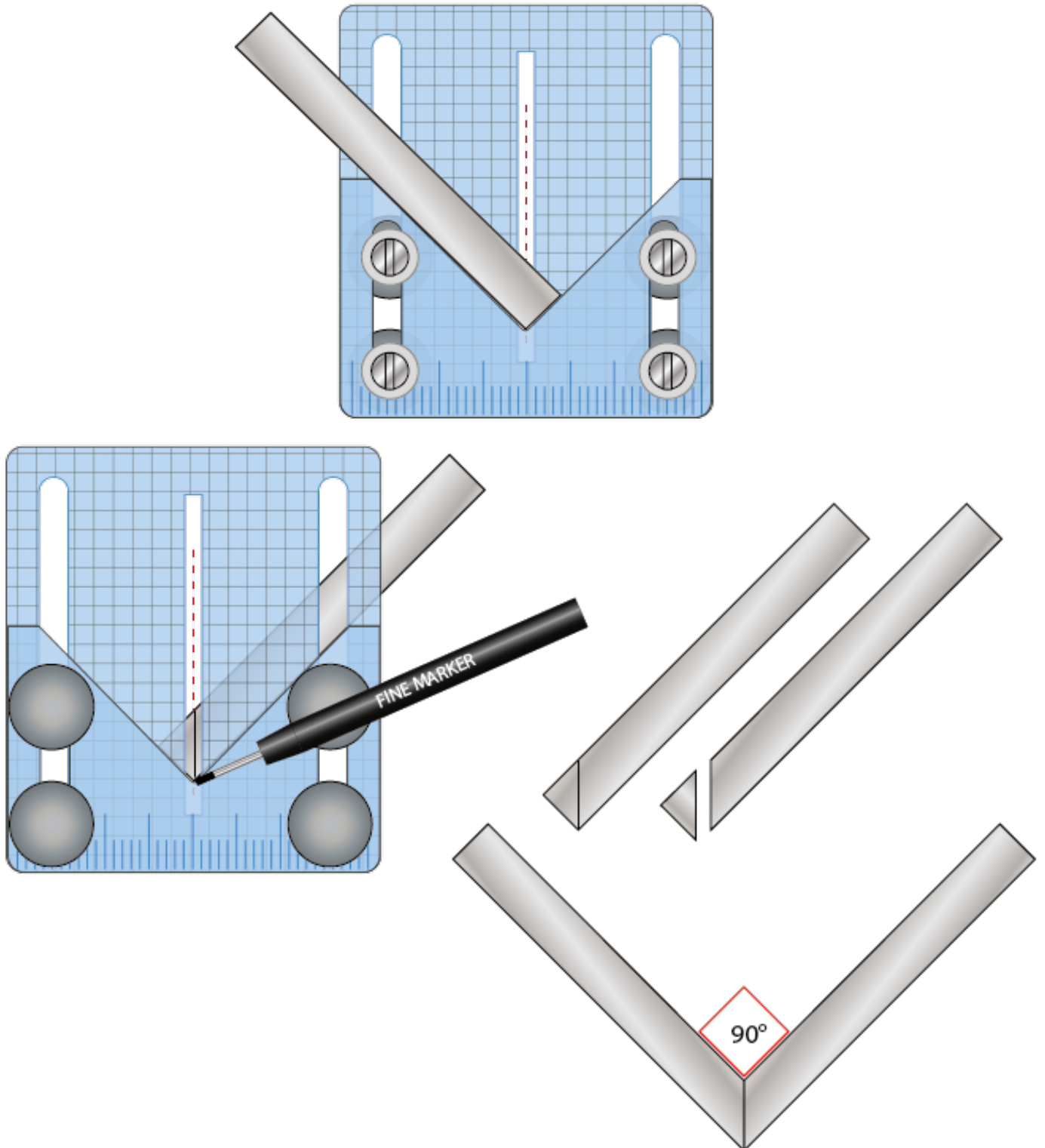

Irregular

For irregular items which are not perfectly circular or square, choosing a central line is largely down to your own taste, but you can use the gridlines to help find a center line you like. The big advantage of the Pepetools jig is that it is transparent, allowing you to see the center line, the grid, and the item underneath. The gridlines are etched into the acrylic, so won't fade or rub off. Count the squares at the left and right-hand sides to see that the item is centralized. Likewise with ovals and oval cabochons, use the gridlines, to position the oval centrally with the top and bottom points in line with the center slot. Mark the center line and rotate 90° to find the center spot.

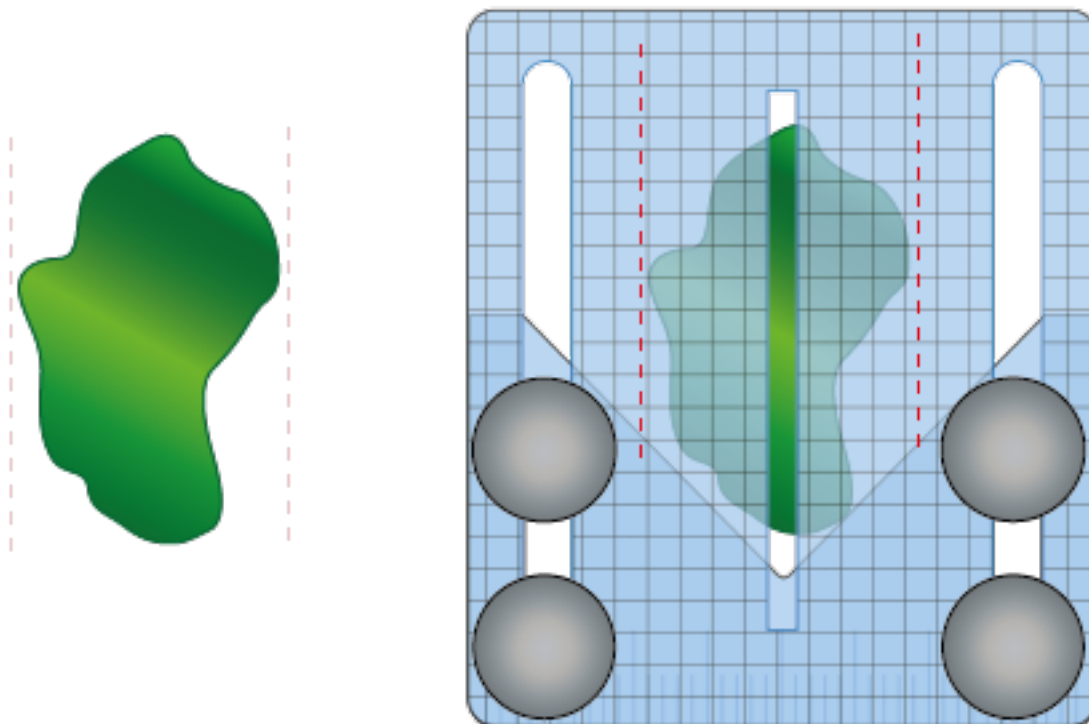

General Tips: -

If the jig should ever come loose, simply align the bottom edges on a flat surface and tighten the screws.

Coin rings. When making folded coin rings, the coin must be drilled in the exact center, people use many bizarre methods to do this, but now you can mark the center with accuracy, every time with just two lines.

Note the bottom of the jig also incorporates a small rule for quick and easy measuring.

If you are using a fine-tip permanent marker, it can easily be wiped off the metal with alcohol (methylated spirits) on a tissue, after you've drilled the hole.

The jig is a perfect companion to the Pepetools Disc cutter, oval disc cutter, and center positioning dies. Having stamped out your disc, it's quick and easy to mark the center line, for drilling holes or adding bails or connectors.

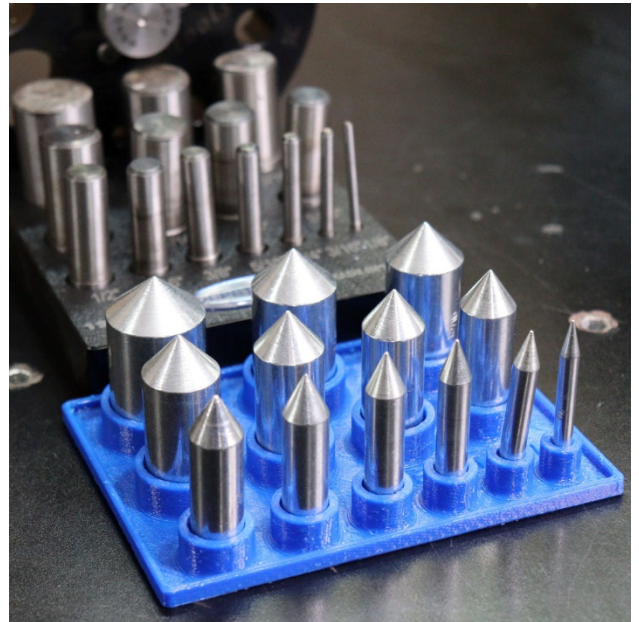

Pepetools Premium Disc cutter and center positioning dies. For punching out perfect circles, and washer components. For a comprehensive range of disc cutters, oval cutters, and center positioning dies, along with Pepe lube and brass mallets, Check out www.Pepetools.com.

Written & illustrated by Dave Wilson

For Pepetools.

V 1.0 11-04-2023



www.Pepetools.com

Contacts

Whatever social media platform you use, Pepetools is right there. Follow us for the latest updates, news, and information on all your favorite Pepetools products. So, check us out and see what's new. Alternatively, you can call us, or simply write. However you get in touch, we look forward to hearing from you.

Kind regards, Pepetools USA.



Check out Pepe's YouTube channel for projects, demos, tips, and reviews. Featuring the best jewelers from around the world, sharing their knowledge with you.



Find us on Facebook. Get in touch, chat, share ideas, and see what's new.

<https://www.facebook.com/PepeTools/>



Follow our blog with up to the minute news and info.

<https://pepetools.wordpress.com/>



Follow us on Twitter.

https://twitter.com/PepeTools_USA



The Pepetools Website with our full product range, info on trade shows, dealer locator and much more.

<http://pepetools.com/>

Pepetools - International Headquarters
7601 S.W. 34th Street
Oklahoma City, OK 73179
USA

Phone: 405-745-4054

Fax: 405-745-4335

E-mail: info@pepetools.com



Center Finder Layout Jig

